

Unit 3

Egyptian Geometry and Volume

Math 116

Math 116

Geometry unit

Volume

Volume The amount of space occupied a three dimensional object.

Volume and Surface Area of Different Shapes

Geometric Shapes

- 1) Rectangular Solid
- 2) Cylinder
- 3) Pyramid
- 4) Cone
- 5) Sphere

Rectangular Solid

A rectangular solid has the property that every cross section, or slice, taken parallel to the base produces an identical rectangle. It is precisely this property that allows us to calculate the volume by take the product of the height and the area of the base, or the product of the length, width and height.

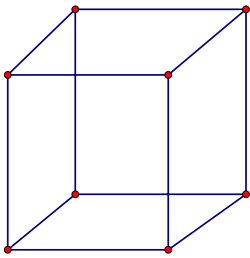

Volume: $V = lwh$

Surface Area: $A = 2lw + 2hl + 2hw$

Cylinder

Using the same principle, we can discover that the same technique to find the volume of the rectangular solid can be used to find the volume of the cylinder. The cross sections of the cylinder turn out to be circles, so the volume of a cylinder can be found by multiplying the height times the area of the circular shaped base. $V = \pi r^2 h$

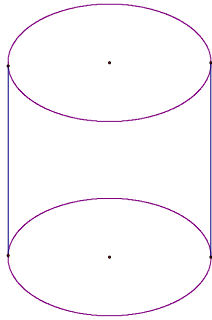

Volume: $V = \pi r^2 h$

Surface Area: $A = 2\pi r h + 2\pi r^2$

Sphere

A **sphere** is a three dimensional counterpart to the circle. A sphere is defined as the set of all points in space that are equidistant from a fixed point called the **center**.

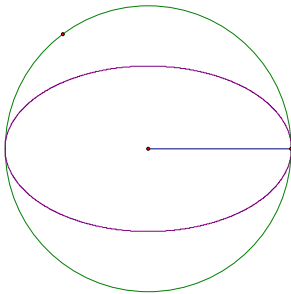

Volume: $V = \frac{4}{3} \pi r^3$

Surface Area: $A = 4\pi r^2$

Cone

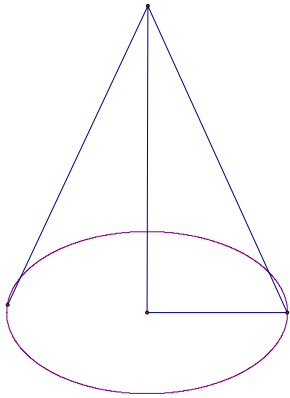

$$\text{Volume: } V = \frac{1}{3} \pi r^2 h$$

The pyramid

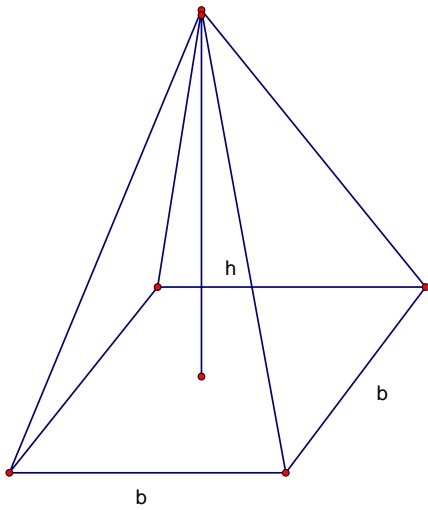

$$V = \frac{1}{3} b^2 h$$

Examples

1) Find the volume and surface area

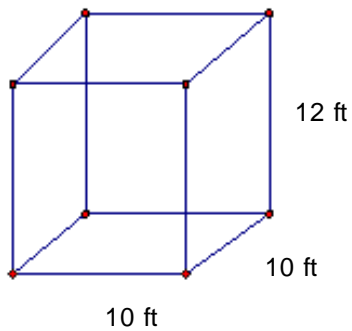

$$V = lwh = (10\text{ ft})(10\text{ ft})(12\text{ ft}) = 1200\text{ ft}^3$$

$$A = 2(10)(10) + 2(10)(12) + 2(10)(12) = 200 + 240 + 240 = 680\text{ ft}^2$$

2) Find the volume and surface area

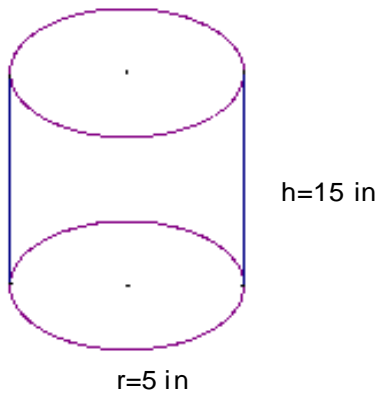

$$\text{Volume: } V = \pi(5\text{ in})^2(15\text{ in}) = 3.14(25\text{ in}^2)(15\text{ in}) = 1177.5\text{ in}^3$$

$$\text{Surface Area: } A = 2\pi(5\text{ in})^2 + 2\pi(5\text{ in})(15\text{ in}) = 157.5\text{ in}^2 + 471\text{ in}^2 = 628.5\text{ in}^2$$

3) Find the volume and surface area

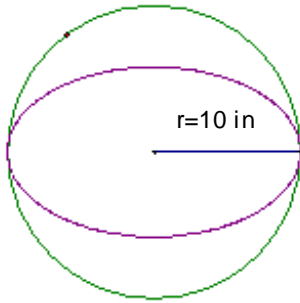

$$V = \frac{4}{3}\pi(10\text{in})^3 = \frac{4}{3}(3.14)(1000\text{in}^3) = 4186.7\text{in}^3$$

$$A = 4\pi(10\text{in})^2 = 4(3.14)(100\text{in}^2) = 1256\text{in}^2$$

20)

Tennis Ball

$$d = 2.5\text{in}$$

$$r = 1.25\text{in}$$

$$V = \frac{4}{3}\pi(1.25)^3 = \frac{4}{3}(3.14)(1.953125\text{in}^3) = 8.2\text{in}^3$$

$$A = 4\pi(1.25\text{in})^2 = 19.625\text{in}^2$$

Ping-pong Ball

$$d = 1.5\text{in}$$

$$r = .75\text{in}$$

$$V = \frac{4}{3}\pi(.75)^3 = \frac{4}{3}(3.14)(.421875\text{in}^3) = 1.8\text{in}^3$$

$$A = 4\pi(.75\text{in})^2 = 7.065\text{in}^2$$

24)

Jupiter

$$d = 88,640 \text{ miles}$$

$$r = 44,320 \text{ miles}$$

$$V = \frac{4}{3} \pi (44,320)^3 \approx 3.64 \times 10^{14} \text{ mi}^3$$

Pluto

$$d = 1500 \text{ miles}$$

$$r = 750 \text{ miles}$$

$$V = \frac{4}{3} \pi (750)^3 = 1767145868 \text{ miles}^3 \approx 1.77 \times 10^9 \text{ mi}^3$$

$$\frac{3.64 \times 10^{14} \text{ miles}}{1.77 \times 10^9 \text{ miles}} \approx 206355$$

- 1) A rectangular fish tank is 7 feet by 6 feet by 4 feet. What is the surface area and volume of the fish tank

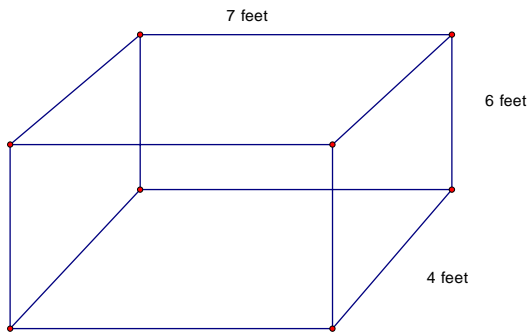

Volume

$$V = lwh = (7 \text{ ft})(4 \text{ ft})(6 \text{ ft}) = 168 \text{ ft}^3$$

Surface Area

$$A = 2lw + 2hl + 2wh = 2(7 \text{ ft})(4 \text{ ft}) + 2(6 \text{ ft})(7 \text{ ft}) + 2(4 \text{ ft})(6 \text{ ft}) = 56 \text{ ft}^2 + 84 \text{ ft}^2 + 48 \text{ ft}^2 = 188 \text{ ft}^2$$

- 2) A cylinder shaped city water tower has a height of 25 meters and a radius of 15 meters. How much water can this tower hold?

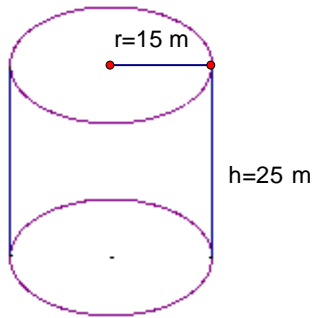

$$V = \pi r^2 h$$

$$V = (3.14)(15)^2(25)$$

$$V = (3.14)(225)(25)$$

$$V = (706.5)(25)$$

$$V = 17662.5 \text{ m}^3$$

Egyptian Geometry

In Egyptian society, they used mathematics to survey the land. During this time period most Egyptians lived on the fertile banks on the Nile. This created problems because the river often flood it banks. As a result, the Egyptians had to know survey their property using geometric shapes. The Egyptians often used ropes to measure out 3-4-5 right triangle which could be used to measure out a perfect right angle.

Measurement

Egyptian Units of Measurement

1 cubit = 7 palms

1 palms = 4 fingers

1 khet = 100 cubits “Greek Aurora”

1 setat = 1square khet = 10,000 square cubits

1 kher = $\frac{2}{3}$ cubic cubit

Cubit is the distance from the tip of your middle finger to your elbow

1 Cubit = 461 mm

Volume

The pyramid

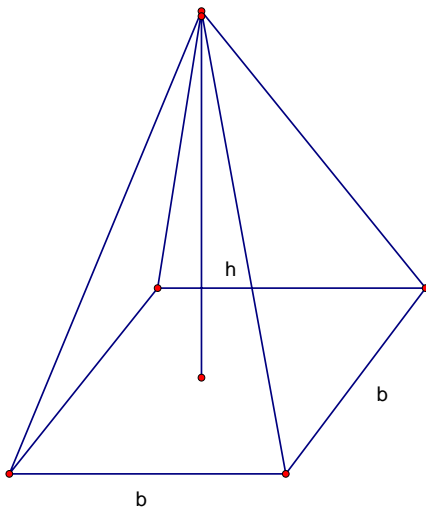

$$V = \frac{1}{3}b^2h$$

The Truncated Pyramid

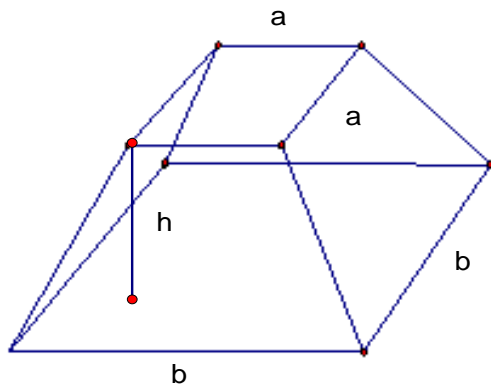

Volume

$$V = \frac{h}{3}(a^2 + ab + b^2)$$

Example from pages 181-182

6)

a) Truncated Pyramid

$h = 33$ cubits

$a = 6$ cubits

$b = 30$ cubits

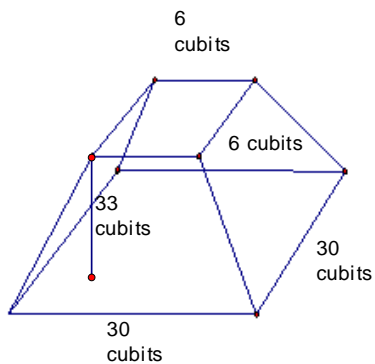

$$V = \frac{h}{3}(b^2 + ab + a^2) = \frac{33}{3}(30^2 + 30(6) + 6^2) = 11(900 + 180 + 36) = 11(1116) = 12276 \text{ cubits}$$

b)

Regular Pyramid

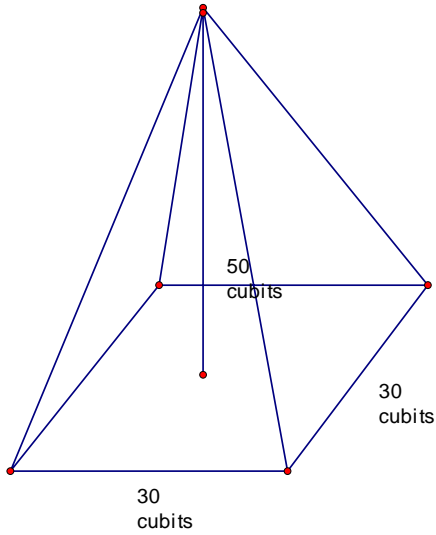

$$V = \frac{1}{3}b^2h = \frac{1}{3}(30)^2(50) = \frac{1}{3}(900)(50) = 300(50) = 15000 \text{ cubits}$$

The regular pyramid has a larger volume

The Egyptian Value for Pi (π)

$$\pi = \frac{256}{81}$$

Area of the a circle

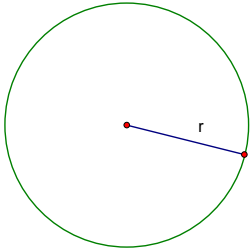

$$A = \pi r^2$$

14) a) Using $\frac{256}{81}$ as Pi

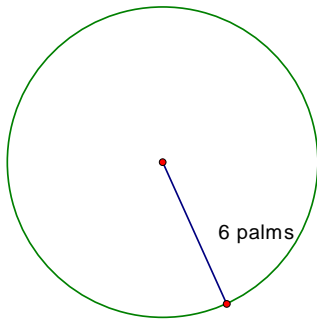

$$A = \pi r^2 = \frac{256}{81} (6 \text{ palms})^2 = \frac{256}{81} (36 \text{ square palms}) = \frac{1024}{9} \text{ palms} = 113.78 \text{ palms}$$

b) Using 3.14 for Pi $A = \pi(6)^2 = 113.10 \text{ palms}$

20)

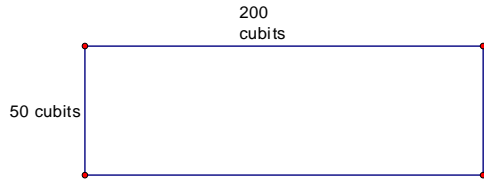

Area in cubits: $A = (200 \text{ cubits})(50 \text{ cubits}) = 10,000 \text{ cubits}$

Area in setats: $10,000 \text{ cubits} \cdot \frac{1 \text{ setat}}{10000 \text{ cubits}} = 1 \text{ setat}$

Does the figure determine a right triangle?

1)

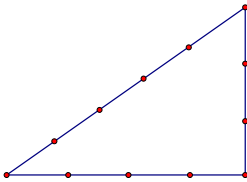

Count the links joint by the pairs of knots which gives the following measurements

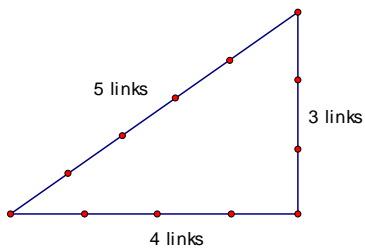

Using the Pythagorean Theorem you get that the triangle is a right triangle

$$c^2 = a^2 + b^2$$

$$5^2 = 3^2 + 4^2$$

$$25 = 9 + 16$$

$$25 = 25$$

2)

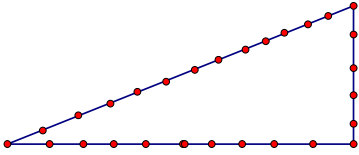

Solution:

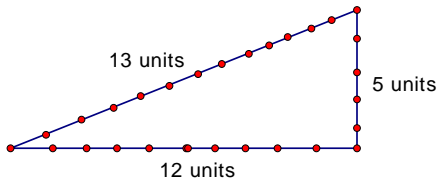

$$c^2 = a^2 + b^2$$

$$13^2 = 5^2 + 12^2$$

$$169 = 25 + 144$$

$$169 = 169$$