

GENERAL POLICY

1. All specifications shall be per CSI format, printed on front and back, and show the full project title, project number and date on front cover.
2. The owner reserves the right to require bonds on performance and labor materials on projects less than \$100,000.
3. Owner prefers that all project as-built plans and specifications be prepared on CADD or software compatible with AutoCAD release 2006 and Microsoft Word. A copy of CD(s)/DVD containing such information is to be distributed to the owner at the end of the project.
4. The owner requires one set of reproducible as-built plans on Mylar material of standard sheet size (i.e. 24" x 36", 30" x 42", etc.).
5. In Facility design, consideration shall be given for trash room and/or maintenance closet space requirements.
6. Construction and renovation projects shall be designed and constructed consistent with the energy performance standards at least as stringent as the US Green Building Council's LEED rating system (including the use of Virginia forest products with alternate certifications) or the United States Environmental Protection Agency/Department of Energy's "Energy Star" rating. Other components of sustainable and green building concepts shall also be used where attainable.
7. Logo Graphic Identity: Font Weiss; Red is the official color of Radford University use Pantone® 186 for red. RU red can be produced in four-color process using the following formula: $C=10$, $M=100$, $Y=90$, $K=0$. The logo may appear in two forms, with or without "Radford University." If using "RU" only, the full name of the university should appear prominently in close proximity to the logo.
8. Follow the Construction and Professional Services Manual (CPSM) for sample newspaper advertisement. Use Invitation Bid sample for inclusion in project manual.
9. Prior to advertisement, Radford University will select bid dates.
10. Plans and specifications are to be distributed to F.W. Dodge, Colonade Corp. Center Building A, Suite 102, 2840 Electric Road, Roanoke, Va 24015 and Valley Construction News, P.O. Box 791, Roanoke, Va 24016.

DIVISION 1
GENERAL REQUIREMENTS

Handicap requirements must comply with ADAAG, 7/23/2004.

Shop drawings – The owner requires a minimum of two sets of shop drawings, to be submitted to the owner during the course of the project.

Include the following language on projects involving access to confined spaces:

“Contractors are expected to comply with Virginia’s Confined Space Standards. This includes provisions for atmosphere testing, employee training, permits and rescue procedures.”

Disposal Permit – The contractor shall secure a disposal permit prior to demolition or construction. The permit will be issued through the office of Facilities Planning and Construction. Disposal costs, at the local landfill, shall be paid by the contractor unless otherwise specified. Contractors are expected to comply with state and local regulations concerning the disposal of hazardous material or chemicals. The exception to the above mentioned disposal permit would be disposal of inert debris (concrete, brick, etc.) which may be disposed of in the City of Radford or neighboring jurisdiction. A copy of written approval from the receiving jurisdiction authority shall be forwarded to the office of Facilities Planning and Construction.

Public-Right-of-Way Permit – The contractor shall obtain through the Owner a City of Radford permit for activities within public right-of-way. The contractor shall provide to the owner details (drawings, specifications, etc.) of activity, value of executed work, traffic control, and flagging requirements and other pertinent information particular to the proposed work. The contractor shall provide a bond in the amount equal to the value of the work in the right-of-way naming the City as obligee.

DIVISION 2 **SITE WORK**

Soil Erosion – Site must comply with the Department of Conservation and Recreation (DCR) soil erosion measures.

Seeding Materials –

In lieu of on-site seeding the university prefers the documents require the contractor to place sod at all disturbed areas at the end of the project. Sod seed mix shall be as described below (Appendix A-1):

Sod – 45 percent Rebel II Tall Fescue, 40 percent Bonanza Tall Fescue, 5 percent Baron Kentucky Bluegrass, or approval equal.

Where on-site seeding is permitted the below apply:

Fertilizer- Fertilizer shall be granular, non-burning product composed of not less than 50 percent organic, slow acting, guaranteed analysis professional fertilizer. The product shall consist of 10 percent nitrogen, 10 percent phosphoric acid, and 10 percent potash by weight.

Mulch- (1) Clean oat or wheat straw well seasoned before bailing, free from mature seed-bearing stalks or roots of prohibited or noxious weeds. (2) Excelsior blanket shall be chemical free, smolder-resistant with consistent thickness, and the top covered by a photo/biodegradable extruded plastic mesh. Blanket shall be installed with staples made of wire, nine one-thousandths inch in diameter or greater, “U” shaped with six inches in length and a one inch crown.

Site Preparation for Sod and On-Site Seeding –

All ditches shall be back-filled and compacted in six inch lifts.

Prior to seeding or sod installation loosen topsoil to a minimum depth of six inches. Remove stones over one inch in any dimensions, sticks, roots, rubbish, and extraneous matter.

Grade areas to a smooth, free-draining even surface such that disturbed areas blend with the existing grade.

Backfill against a sidewalk should be even with top of sidewalk.

Installation –

Seeding- Seed immediately after preparation of bed.

Apply seed with rotary or drop type spreader. Install seed evenly by sowing equal quantities in two directions, at right angles to each other.

Sow grass seed in six pounds per 1000 square feet.

Incorporate seed into the top 1/8 inch of soil by raking, dragging, rolling, or hydro-seeding.

Apply fertilizer at a rate equal to one pound of actual nitrogen per 1000 square feet (1/3 of product shall be SCU or IBDU).

Mulching- Place straw on seeded areas within 24 hours after seeding.

Place straw mulch uniformly in a continuous blanket at the rate of two bales per 1,000 square feet of area. A mechanical blower may be used for straw mulch if so desired by the contractor. If loose straw is used, it must be netted or tacked with hydro mulch.

Cleaning-

Perform cleaning during installation of the work and upon completion of the work. Remove from site all excess materials, debris, and equipment. Repair all damages resulting from construction and seeding operations. Pressure wash all paved surfaces.

Acceptance- All seeded areas will be inspected at completion of installation and accepted subject to compliance with specified materials and installation requirement.

Guarantee- All seeded areas shall have a minimum 95 percent coverage with the desired species of Bluegrass and Perennial Ryegrass after seed has germinated. The contractor shall be responsible for repairing areas with less than 95 percent and areas where settling has occurred.

Concrete Walks-

(See appendix sheet A2-A4) Air entrained concrete type A3 with fibermesh, typical. WWF not required.

Walks, eight feet or wider or subject to vehicle traffic, shall be six inches nominal depth. No walk shall be less than 5 feet wide.

Wherever possible, grades of walks and ramps shall be in accordance with ADAAG handicap standards.

Expansion joints shall be doweled.

Broom finish surfaces and tool edge joints including control joints.

Control joints shall be every five feet and shall be tooled.

Walks shall be sealed with a curing compound and protected from weather for 24 hours.

Signage-

Exterior handicap signage shall be mounted on pre-drilled metal channel sign posts at a height per ADAAG.

DIVISION 3
CONCRETE

Concrete slabs- See walks above.

Additive- No cold weather additives shall be permitted.

Exterior Concrete- Shall be air entrained concrete type A3 with fibermesh. WWF not required.

DIVISION 4
MASONRY

NOTE: No masonry work shall occur when temperature is below 40 degrees Fahrenheit.

Brick shall be selected on a per building basis, per mock-up. Following are some examples of brick and mortar colors used on campus:

Peters Hall – Standard Olde Virginia Pastel Mingle Shades by Salem Brick Co. and Webster Brick # 305 Roanoke. Mortar is Flamingo ASTM C270 types.

Muse Hall – Webster Brick # 554 from Factory 10, Summerset, Virginia.

Dalton Hall – Olde Virginia Brick style EFM, size S, lot 0116. Mortar type S, custom color C-73 Flamingo.

DIVISION 5
METALS

Metal Rails- Shall be in compliance with ADAAG when used as handrail. Square stock may be used as guardrail only. All rails shall be primed and painted (off-white matching other campus rails, unless otherwise indicated) or pre-finished.

DIVISION 6
WOOD & PLASTIC

DIVISION 7
THERMAL & MOISTURE PROTECTION

Insulation- All concealed spaces in exterior walls in excess of ½ inch in width shall be insulated.

Roofing-

Shingle roofing – Simulated slate.

Membrane Roofing – Fully adhered EPDM. Provide walkway pads for access to roof mounted equipment.

DIVISION 8 **DOORS & WINDOWS**

Hardware-

Locksets- By Best Lock Corporation (Preferred). List first when naming manufacturers and have schedule reflect Best on specifications. 93 K series with 15D lever handles.

Keying shall match existing campus-wide system. Permanent core and keys shall be sent to owner by Best. The owner will install permanent cores and return construction cores to Best Lock. Finish 626 (satin chrome) typical in new construction, verify existing in building renovation projects, often satin bronze. Locksets generally shall be cylindrical in lieu of mortise. Provide Best 7-pin interchangeable core cylinders at all locations. Mark each core in a concealed place on the core (when the core is installed). Provide brass construction cores at all locations for use during construction. Locks shall be ANSI A156.2, Series 4000 Grade 1. Minimum of a three year factory warranty. Latch throw shall be minimum of 9/16 inch. Provide ¾ inch throw anti-friction latch bolts at exterior doors and fire doors, where specified. Provide 3 cut keys per each core.

Classrooms and assembly areas (conference and meeting rooms) – Shall have dormitory function push button inside to secure door – must be locked with key when leaving - locksets. The knobs can be “either” mortise or cylindrical.

*Best 9K-T
Yale 5400LN
Sargent Lever Lock*

Exit Devices – Rim Type preferred with mullion rather than vertical rod.

*626 (New) 612 (satin bronze) renovation, verify.
Russwin 736
Corbin 372
Von Duprin (prefer “33” Type II)*

Center Mullion – Double doors shall have removable mullion where practical. Confirm door and frame preparation requirements with campus card access system.

All entry doors shall be prepared for card entry access.

Thresholds – ½ inch maximum beveled rise with non-slip abrasive surface, meeting ADAAG standard.

Closures – LCN Series 4011 or 4111 adjustable hydraulic back check, parallel arm mounting preferred. Five-year warranty or equal.

Door stops – Specify concave wall stops in lieu of floor mounted stops, where possible.

Doors

Bi-fold doors preferred over track bypassing doors.

Standard interior doors shall be red oak or birch plain sliced, A W1 premium grade.

Window Frames- Aluminum heavy commercial grade. Style and operation to match existing in replacement projects (unless otherwise approved). Baked enamel or finish coating color, to match campus standard paint color.

Glazing- Insulating glass, typical, factory fabricated unit, 1 inch air space. Maximum of 17.5 percent of exterior wall area shall be glazed, unless otherwise approved.

DIVISION 9
FINISHES

Acoustical ceilings- Lay-in 24 inch by 24 inch ceiling tile (preferred). Use of tegular edge tiles must be approved by Radford University prior to inclusion in project specifications.

NOTE: Bulkheads shall be constructed of gypsum drywall.

Ceramic Tile- Preferred floor and wainscot in toilet areas. Sanitary cove base, typical on ceramic and quarry tile areas.

Resilient Floor Tile- 12 inches by 12 inches by 1/8 inch typical, with alternating pattern.

Base- Rubber, four inches high, cove 1/2 inch minimum depth, unless otherwise approved. Specify roll lengths where practical. Base in carpeted areas to be installed following carpet installation. Do not specify preformed comer or end pieces.

Stair Treads- Rubber, full width of stair, with reinforced rubber nosing.

Painting- Semi-gloss finish, typical on all trim and also wall paint in active public spaces.

Carpet- By owner, under state contract. Contractor to furnish and install base after owner installed carpet.

DIVISION 10
SPECIALTIES

Fire Ext. Cab- Semi-recessed with ten pound canister capacity. Specify one per 3,000 square feet mounting height, to be ADAAG accessible.

Toilet Partitions- Floor supported (including urinal screens) overhead braced. Solid plastic partitions preferred, by Santana, Scranton, FA, or equal (Manufactured from recycled material).

Toilet Accessories-

Tissue Dispenser – JRT, Jumbo roll dispenser. Handicap shall have two roll dispensers with non-restricted flow. Dispenser shall be furnished by the owner and installed by the contractor.

Liquid soap dispenser – Provided by owner. Installed by contractor.

Towel dispenser – Surface mounted minimum capacity 350 “C” fold or 475 multi-fold paper towels. If stainless steel receptacles are integral, container must be removable.

Floor basins – Housekeeping closets, rigid, molded PVC or terrazzo.

Mirrors – To have shelves. Tilt mirrors in handicap accessible location not desired. Mount standard mirror at appropriate height. Recommended 18”x 36” standard mirror size.

DIVISION 11
EQUIPMENT

DIVISION 12
FURNISHINGS

Window coverings- Confirm if in general construction contract. Venetian blinds, one inch pre-finished aluminum.

Signage- Confirm if in general construction contract. Generally ADAAG required signage in contract and specified by Architect.

DIVISION 15 **MECHANICAL**

Piping

Mechanical- shall be color coded in accordance with American National Standards Institute (ANSI) A13.1-1981.

Below grade- is to be Bell and Spigot with neoprene gasket.

Concealed valves/cut off- locations shall be coordinated with ceiling, wall access panels, and piping to allow access.

Interior Sanitary- shall be cast iron with no hub connections.

Steam Lines-

Direct burial of steam lines is not permitted. Provide a concrete/masonry trench or tunnel. Walk-thru tunnel is preferred.

Install steam traps on a low pressure steam system so that return is by gravity to receiver.

Prefer to have steam condensate lines located so return will be gravity to steam tunnel there by not requiring a condensate pump.

If steam condensate pump is required, a steam driven pump shall be used.

Install test port and strainer on all steam trap lines (high and low pressure).

No galvanized fittings on steam lines.

Identification-

Stencil letters and arrows on pipes and equipment (do not use snap-on markers or pressure-sensitive markers).

Engraved plastic-laminated signs and markers must be glued and screwed or pop-riveted to equipment.

Automatic Air Vents – should be installed in the highest points of the system.

Pressure Relief Valves- pipe pressure relief valves outside of mechanical room per ASHRE standards.

Portable Water- protect portable water with RPZ cross-connection.

Sprinkler Systems- Hydraulically designed wet pipe automatic system, typical, unless otherwise approved. Dry-pipe systems in attic areas are acceptable where subject to freezing. Provide RPZ where connected to City of Radford system. Back-flow preventers must meet requirements of City of Radford Ordinance. Water flow test shall be the responsibility of the Contractor. A/E will provide estimated GPM, static pressure, and residual pressure for bid purpose with the stipulation that the system will be designed from final test data.

Provide zone valves in chill, heating, and dual temperature piping.

Air Compressors- Oil filled reciprocating.

Ice Storage Tanks- Calmac preferred.

Water Heaters- Armstrong Flo-Rite-Temp packaged Instantaneous Water Heater with Thermostatic Mixing Valve or approved equal.

Fixtures -

Lavatories- Shall be wall hung, enamel cast iron unless otherwise approved. Single lever fittings for lavatories in residence halls to be short handle type.

Water closets- Wall hung standard.

Plumbing fixtures- Use American Standard, Kohler, and Eljer as design standards. Use Sloan, Zurn, and Delany flush valve as design standards. Use American Standard, Kohler, Chicago Faucet, Eljer, Speakman, Moen, or Delta as standard faucets. Provide mop-basins, floor mounted, in lieu of sinks.

HVAC- Economizer cycle shall be used when room/space requirements would not be jeopardized. Provide cooling for data equipment rooms. Request equipment load from Radford University.

Expansion tanks- Bladder type.

VAC Systems-

Variable frequency drives preferred on air handling units. Drive capable of auto reset upon alarm clearance.

Variable air volume units shall have a 1-10 volt damper motor and a flow ring mounted on the inlet side. Hot water heating coil mounted in the duct on the outlet side of box.

Prefer to use parallel boxes. Series boxes only in special situations.

Mechanical Insulation- All piping insulation on domestic cold water, chill water, and dual temperature shall be continuous (see Appendix A-5).

Dielectric Fitting- Required when transitioning between incompatible materials.

Plumbing Specialties -

Vacuum Breakers should be provided on outside faucets and janitor sinks. Air-gap or anti-siphon device where water line could be suspect to chemicals.

Water hammer arresters are to be provided.

Where showers and commodes are on the same system the line should be sized large enough to prevent shower scalding when commode is flushed.

Install RPZ on water make-up for heating, chill water, and cooling tower water.

Natural Gas Piping- Equipment, regulators, and piping should be specified dependent on service and pressure available from local gas company's equipment. Gas Company is to install line to building and furnish meter. Contractor is to run line from meter to all equipment.

Hydronic Piping- Provide chemical feeders and appropriate valves on hot water and chill water systems.

Chillers-

Chiller shall be multi-staged reciprocating or screw type. R-134A refrigerant. Prefer screw type. *Provide five (5) year compressor warranty.*

Prefer configuration of chiller to be such that the compressors and chilled water barrel are located in the mechanical room and condenser or cooling tower located outside. Air colled condenser preferred.

Hot-gas-bypass is not acceptable.

Chiller shall include the manufacturers' standard diagnostic package. The chiller controls shall be capable of resetting in 10-15 percent of full load. Provide capability of providing the following:

Resetting the chiller water supply temperature from an external 1-10 VDC signal.

Chiller alarm contacts to external source.

Start – Stop function from external source.

Status of operation of chiller.

The building automation system (BAS) shall control the start and stopping of the chilled water pumps. A water flow switch shall be provided in the line for chiller to sense flow before starting.

If air type condensing unit is used, its control is directly form the chiller not BAS.

If cooling tower is required, building automation will control the operation.

Prefer Variable Frequency Drives on cooling tower pumps as opposed to mixing valve.

Anti-freeze shall be propylene glycol, not ethylene.

Ice storage controls shall be controlled by the building automation system.

Separate ice making control package with chiller is not required.

Provide heat exchanger in ice storage system to keep glycol in mechanical room only and not circulating throughout the building.

Circulator Pumps-

Shall have mechanical seals and replaceable rubber couplings. Seals, bearings, and impellers should be changeable without removing pump housing from building piping.

Prefer mounted on concrete base.

Provide two pumps with each pump having 100 percent pumping capability. Pumps shall be operated in a lead-lag mode.

Water-tube Boilers-

Shall be capable of being controlled from energy management system. Control of hot water supply shall be accomplished by energy management system.

Check with local gas company for pressure requirements.

Air Handling Units-

Double wall construction with solid galvanized steel interior panels. Fan/motor assembly to be mounted on internal isolators.

Variable frequency drives, as opposed to vortex dampers, controlled by Building Automation System.

Motors should be energy efficient.

Dampers shall be low-leakage.

Damper operators shall be digital. Filters shall be two inch pleated pre-filter, 12 inch frame or bag filters to obtain maximum efficiency.

Provide minimum outside air duct to supply exhaust needs. Minimum duct shall have an air flow station connected to the building automation system (see Appendix A-7 and A-9).

Provide for 100 percent outside air capability. Prefer outside air intake grills to be mounted above ground level and away from automobile fumes, etc.

Fan Coil Unit-

Shall be 4-pipe with control valves on each coil and controlled by Building Automation System (BAS). Fan shall be energy efficient and controlled by the BAS. Fan speed shall be set on one speed, as determined by balancing contractor, and BAS shall cycle on and off.

Where units have outside dampers, a freeze protection control shall be used as well as low limit control.

Drain pan switches shall be used and wired to the BAS.

Plate Type Heat Exchanger- The exchanger shall be used in ice storage systems for “free cooling” when a cooling tower is used. In ice storage systems, the exchanger is used to separate the glycol from the water in the building system. When a cooling tower is used, the exchanger is used to transfer water temperature from the tower to the building system.

Metal Ductwork-

Shall be insulated on exterior. Vapor barrier on the insulation shall be continuous with no areas open to the air.

If perforated duct is used for reduction of noise, there shall be a layer of Mylar between perforation and insulation.

Provide manual balancing damper at main duct take-off **not** at registers.

Size duct work such that air and distribution noise does not exceed 45 db sound pressure level.

DIVISION 16 **ELECTRICAL**

Lamps and Ballasts- Energy saving type, electronic ballast, T-8 fluorescent tubes, typical. Tubes shall be Low-Mercury Lamps: complying with EPA's toxicity characteristic leaching procedure test; shall yield less than 0.2 mg of mercury per liter when tested according to NEMA LL 1.

Conduit- Minimum size ¾" EMT inch.

Pumps- Motors are to be energy efficient.

Fixtures-

Interior – two foot by four foot interior fluorescent lighting typical. Do not switch stairway lights.

Exit – Lights shall be LED with battery back-up.

Office and Classroom – Select low glare lens for offices and classrooms. Use of incandescent lamp shall not be used unless approval by university at a specific location.

Exterior – Walkway lighting is to match existing. Fixtures shall be traditional, outdoor light fixture, as manufactured by McGraw-Elison (TR Series, 120-V, HPS 150W). Poles/posts as manufactured by Mainstreet; Harrisonburg series fiberglass lamp post. Finish is to be black in color, painted with polyurethane paint to match core color. Poles are to be 10 feet 9 inches in height and furnished with embedded base. Above is to describe standard of acceptance, other manufacturers are acceptable (see Appendix A-6 for control). Parking lot fixtures are to be 250 HPS on 30 foot poles.

Outside Lighting - All exterior lights shall be controlled by the BAS. Calculates sunrise and sunset and turns the lights on and off at the appropriate times. (See Appendix a-10)

Devices- All devices shall be rated 20 amp minimum. Provide receptacle in stairs.

Panels- Provide 25% spare spaces in the panel for future needs.

Wiring- Copper

Boxes- Shall be installed such that they are **not** back to back.

Equipment grounding- A green ground conductor shall be installed in raceway serving electrical distribution equipment, in branch circuits serving receptacles, and to equipment served by flexible conduit, except lighting fixtures. Ground conductors shall be continuous from the equipment to the ground bus of the switchboard, panel board, or control center serving the equipment.

Motors- shall be energy efficient on all equipment.

Standard Distribution Voltage- 120/208 or 277/480 3 phase.

Distribution System to Building- Provide a concrete duct bank system to connect to the university's existing 4160 volt system. Connect the duct to the nearest high voltage in-ground vault. Provide 4/0 cable as specified by the owner. Duct bank shall terminate at an electric vault connected to the building or at a pad mounted transformer. Provide switching, in the vault or in a separate switch gear on a pad, to provide a continuous loop of the existing system. Transformers shall be provided by the City of Radford Electric Department.

Communication Raceways- Shall be provided. Specifications are to be coordinated with owner.

Fire Alarm System- Shall be an addressable system. Remote signaling to the Police Department in the Allen Building is accomplished by installing Johnson Controls module connected to contacts for trouble and alarm. The Johnson Controls module will be provided by the owner and the owner will make connection to the Police Department. Contractor to make connection from module to fire alarm panel.

DIVISION 17
BUILDING AUTOMATION

Building Automation System (BAS)-

Extend existing BAS to provide direct digital control, and monitoring (typical unless otherwise approved). Existing system is Johnson Controls, Inc. Metasys. The BAS system and installation is a sole source procurement with Johnson Controls, Inc. as the vendor.

The cost for the BAS for a given project will be provided to Radford University for inclusion in the base bid.

Items such as pneumatic dampers, valves, etc. which can be provided by other vendors and remain functional with the BAS shall be specified in the controls section of Division 15.

Control sequences shall follow Johnson Controls pre-programmed sequences when possible. This reduces the cost of programming time.

Network-

The BAS connects to the existing university system by means of the campus Ethernet system. This connection will be provided by the owner.

Control Devices-

The correct control device for a specific application will be selected by Johnson Controls and approved by the owner.

Radford Standard Control Sequences-

Hot Water Converters – Converters shall have two steam control valves, one-third and two-thirds capacity. BAS shall monitor hot water supply and control steam valves using hot water reset from outdoor air. Reset schedule shall be 10-70 outdoor temperature, 80-100 hot water supply. The BAS shall monitor outside air and close the converter valves when the temperature rises above 60 degrees.

Hot Water Pumps – The BAS shall start one of the pumps when an occupied command is sent and the outside air temperature is below 60 degrees. The BAS will sense the differential pressure in the hot water lines at the highest point and send a 0-10 volt signal to the variable frequency drive to control the speed of the pump. Two-way valves shall be used on all the units except for a few three-way valves (1 or 2, on larger units) needed to provide a water supply to the pumps when all valves are closed.

Fan Coil Units – BAS shall control the heating and cooling valves as well as the fan on and off. A thermostat shall be mounted on the wall to control the units. Adjustable thermostats are used in offices and private rooms and non-adjustable thermostats in public areas. If the units have multi-

speed fans, the balancing contractor shall set the correct speed to obtain the designed CFM and the BAS shall turn the fans on and off. If outside air dampers are required, low limit control shall be employed.

Variable Air Volume Boxes - BAS shall sense the pressure from the flow ring and convert to CFM using the information provided from the balancing contractor. BAS shall control the damper motor, parallel or series motor, and the heating valve during occupied periods to maintain space temperature. During unoccupied periods, the fan and heating coil shall maintain unoccupied temperatures.

Air Handling Units –

Constant volume units shall incorporate economizer dampers with up to 100 percent outside air and a separate minimum outside air duct with a damper for exhaust make-up. Also a return (exhaust) fan shall be ducted to the outside and to the return of the AHU with dampers at each location. The BAS shall open the minimum damper to its set position to provide make-up air for building exhaust when the unit is running and close it when the unit shuts down. The economizer damper shall remain closed, return damper open and the exhaust damper closed when the unit is not in economizer mode. A CO₂ sensor located in the return duct shall control the economizer dampers to maintain a 1,000 ppm level of CO₂ in the space. When the system is in the economizer mode, (set below 65 degrees outdoor air) the dampers shall be controlled by a calculated discharge setpoint, with a mixed air flow limit, and mechanical cooling disabled. The BAS shall control the heating valves, cooling valves and pre-heat valves when required.

VAV Air Handling Units shall operate as above with the addition of the following: The CFM shall be controlled by a Variable Frequency Drive on the supply fan and return fan. The supply fan is controlled by measuring the static pressure in the ductwork at two-thirds the total length of the duct. The static pressure setpoint is established by the balancing contractor to supply the required CFM. The return fan speed shall be controlled by sensing the differential pressure in the return duct before the fan and the mixing box on the air handling unit. The differential setpoint is set so as to achieve a slight positive pressure in the building. The minimum outside air duct shall have an air flow measuring station in the ductwork. The BAS senses the flow and controls the minimum outside air damper to maintain the correct CFM required for building exhaust even when the supply fan slows down.

Chillers –

Chillers shall have the manufacturers' standard diagnostic package which has the capability to receive a 0-10 volt signal to reset discharge water temperature, start-stop point, alarm contacts and status contacts. These points are wired to the BAS. The BAS shall start the chilled water pumps and a flow switch mounted in the chilled water line shall signal the chiller of a positive water flow. The BAS shall signal the chiller to start and send a voltage to set the water temperature. The chillers leaving water temperature shall be reset using outdoor air. Reset schedule shall be 65-85 outside air, 45-54 water temperature. The BAS shall monitor the outside air and stop the chiller when the temperature falls below 60 degrees.

Chillers in an ice storage system shall operate as above with additional controls.

Unoccupied mode – The chiller has an ice making mode point which the BAS tells to energize. The BAS starts the pumps, switches the building valve and the chilled water valve into the ice making position. These valves will direct the water into the ice tanks and by-pass the building. The chiller will run in the ice making mode until the BAS senses the tanks are full (from a tank level sensor) and tells the chiller to shut down. The pumps and chiller will stop and wait for an occupied signal from the BAS.

Occupied mode – The BAS will start the pumps, switch the building valve, and modulate the chilled water valve to by-pass tanks. The BAS will have a 10 minute delay before switching the chiller out of ice making mode and starting the chiller. This delay allows for the water in the loop to warm above the freezestat set point in the chiller before starting. The BAS shall calculate the chilled water setpoint by using outside air reset. This set point shall control the chilled water valve to supply the correct temperature to the building. The BAS will add two or three degrees to this setpoint and send the signal to the chiller to produce water that is two or three degrees warmer than the setpoint. This allows the ice to bleed in and use ice while the chiller is uploaded, thus saving energy. The BAS will shut the chiller down on a request for demand limit. This allows the pump and ice to cool the building during this time. NOTE: this happens usually twice a day and lasts for approximately 1 hour.

Chilled Water Pumps – The BAS shall start one of the pumps when an occupied command is set and the outside air temperature is above 60 degrees. The BAS will sense the differential pressure in the chilled water lines at the highest point and send a 0-10 volt signal to the variable frequency drive to control the speed of the pump. Two-way valves shall be used on all the units except for a few three-way valves (1 or 2, on larger units) needed to provide a water supply to the pumps when all valves are closed. (See Appendix A-8)

Steam Flow Meter – Provide a steam flow meter in the main steam line after entering the building. The meter shall be connected to the BAS to record steam usage.

KW/KWH Meter – Provide a KW meter with the CTs mounted in the transformer vault. The meter shall be connected to the BAS to record electrical usage.

Multimedia Classroom Design White Paper

This information is intended to provide architects and other planners with the proper information to configure Multimedia classrooms based on Radford's standard classroom model that has been utilized since 1999. These rooms include a ceiling mounted projector, Visual Presenter, RU CATV, VHS, DVD, and computer with Internet. All inputs are controlled from a central box and viewed from a LCD monitor.

Room Layout

Multimedia Classroom Layout

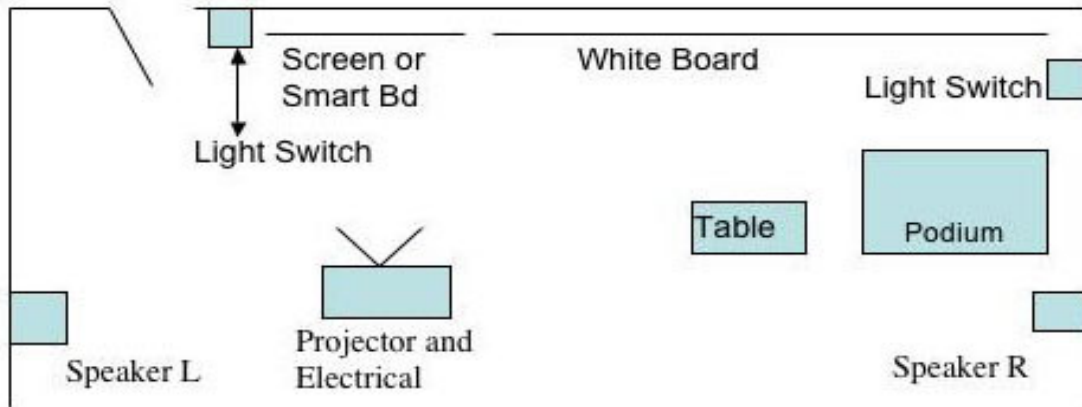

Podium and Table –

Background - The Podium holds all the equipment used in the Multimedia Classroom. The podium footprint is 26" D x 44" W, 38.5" H. A table 20" D x 48" W should be near the podium.

Podium Mounted - The podium should be mounted 48 inches from the front wall, 6 inches off the sidewall. If near a floor mounted fan coil unit, distance the podium 18 inches from the unit. In addition, a table positioned near the podium is required so faculty can place handouts, papers and other materials for students (see Room Layout above).

Podium Wiring Raceway or Conduit - All wires should be placed in raceway or conduits. Wires include CAT5, audio, coax and AC power. See Electronic Classroom Wiring below for type and quantity of wires. The podium requires a double-gang outlet box inside and single-gang outlet receptacle outside the podium. Wires connect to the Network Closet, CATV, projector, and speakers.

Lighting -

Background - For best results, capabilities should exist to dim all lighting in the room. The lights in the front of the room should be switched separately from the lights in the rear of the room. Multimedia Classrooms require at least two switches near the podium and exits. (See Light Switch Pattern below.)

Light Switch Pattern –

- Switch 1 controls lights between the mounted projector and projection screen.
- Switch 2 controls lights behind the mounted projector.

White Marker Boards -

Background - It is important for faculty to have ample writing space at the front of the room. White marker boards (4 feet high) should stretch the full width of the front wall, including behind the podium, preferably seamless for lengths longer than 8 feet. Front White Boards should **not** include tack boards.

White Board Mount - Mount White boards 34 inches up from the floor to reduce projector screen ripping caused by board tray. There should be at least 8 feet between the podium and a mounted screen or Smart Board.

Smart Boards -

Background - Smart Boards are typically 60 inches wide, 48 inches high, with a 72 inch diagonal viewing area. Since the TV aspect ratio is 3 high by 4 wide, the Smart Board projected viewing area will never be wider than 5 feet because the height remains at 48 inches. A Smart Board connects to a computer. See the Projector Mounting below for distance between Smart Board and Projector. An empty conduit should be installed with a single gang box under the projector screen to allow for Smart Board cables.

Smart Board Mounting - The Smart Board should be mounted adjacent to the White Board 34 inches off the floor, at least 8 feet away from the podium. (See Room Layout) Install a conduit in the wall behind the Smart Board to run control cables to the podium. The purchased Smart Board will determine which side (Left or Right) the conduit should be placed.

Projection Screen -

Background - To leave ample writing space when the screen is pulled down, the projection screen should **not** be mounted in the center of the whiteboard. Typically this screen will be on the opposite side of the room from the podium so the projector is not shining directly in the instructor's face when they step away from the podium. Standard glass-bead projection screens are 84" x 84". Depending upon the location of the Projector Lens, left or right of center, will determine the location of the screen. (See Room Layout)

Projection Screen Mounting –

- At least 8 feet of white board space between podium and the projector screen.
- Mount screen close to ceiling, when fully extended, the bottom clears the white board tray.
- Screen handle should have a cord attached, enabling user to pull it down when fully rolled up.

Projector -

Every ceiling mounted projector should have dual AC Power mounted near the projector. See Wiring Diagram below for wire types and quantity that need to run between the Projector and Podium.

Projector Mounting Distances -

- 84" x 84" screen, mount projector 15 feet back.
- 96" x 96" screen, mount projector 26 feet back.
- 60" wide (Smart Board), mount projector 9 feet, 10 inches back.

Speakers -

Speakers use a flush, wall mount. Position them on opposite walls, in front of the Podium, see Room Layout. See Electronic Classroom Wiring for the quantity and wire type.

Conference Room -

In conference rooms sized to accommodate 15 or more people provide a floor box for power and data connections.

Cable C

Electronic Classroom Wiring

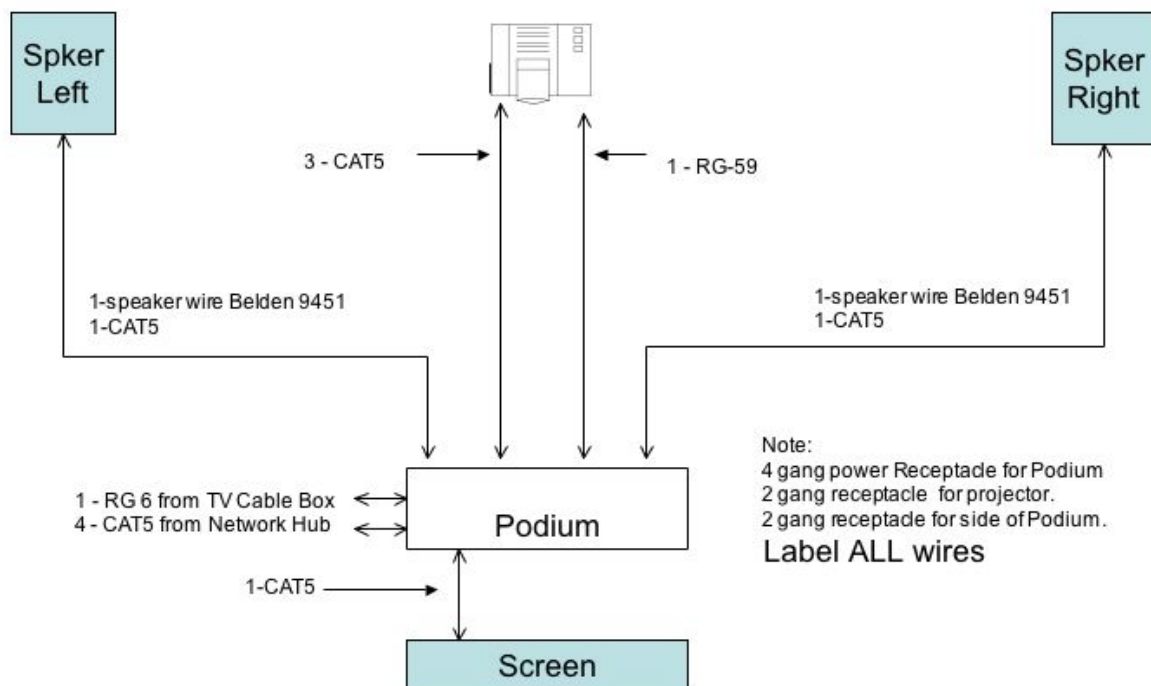

Cable runs above indicate empty conduit from device to device, all conduit shall be 3/4 inch.

Total wiring needs:

- 3 - CAT5 from Podium to projector.
- 1 - RG-59 from Podium to projector.
- 2 - Belden 9451, 1 line each from Podium to each speaker.
- 2 - CAT5, 1 line each from Podium to each speaker (new).
- 1 - RG -6 coax from CATV junction box to Podium.
- 4 - CAT5 from Network closet to Podium.
- 1 - 4 gang Power receptacle for Podium.
- 1 - 2 gang Power receptacle for Projector.
- 1 - 2-gang Power receptacle for Podium, sidewall facing room.

Cabling will be furnished and installed by Radford University. Construction contract to include all line voltage wiring to receptacles and an empty conduit system for data/speaker/control wiring.